

**MINIATURE TYPE**

**OME-N<sub>Model</sub>**



**Miniature Model**

- Easy to Install by Connector.
- It is Possible to Align The Electric Zero With.

**Model**

**OME - [ ] [ ] - [ ] [ ] N - [ ] 00-015-00**

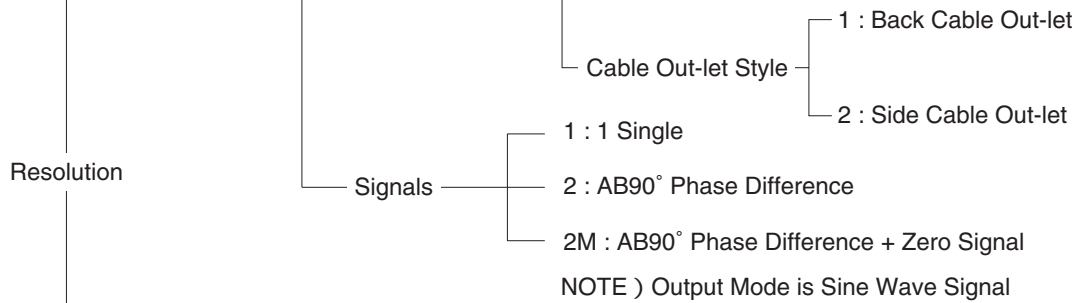

100	100 P/R	200	200 P/R	300	300 P/R
157	157 P/R	250	250 P/R	360	360 P/R
176	176 P/R	256	256 P/R		

**External Dimension**

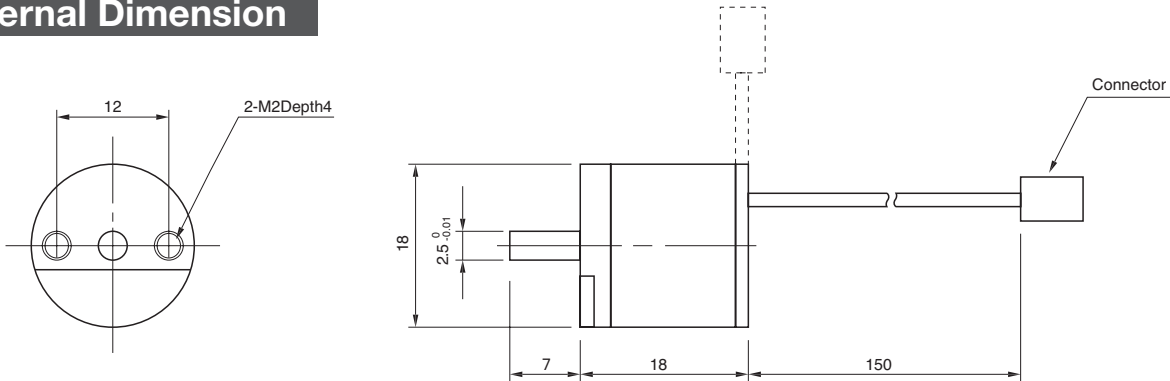

**Circuit of Output Signal**

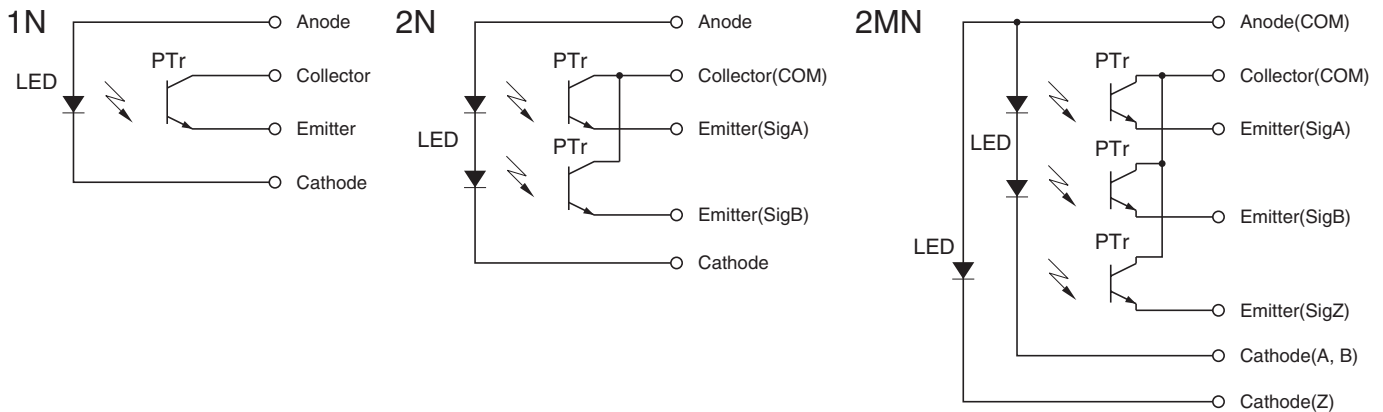

### Electrical Spec.

TYPE	1N	2N	2MN
LED Current	IF = 26 mA Max		
Maximum Frequency Response	10 KHz		
Output Signal Amplitude	150 mVp-p or More		
Output Amplitude Variation	40 % Max		

### Max. Rating of Electronic Elements

LED Light Emitting Diode

Max. Current Flow	IF ; 60 mA
Reverse Voltage	VR ; 4 V
Derate(25 to 70°C)	- 1.73 mW / °C

PTT Photo Transistor

Collector-Emitter Voltage	V <sub>CEO</sub> ; 20 V
Emitter-Collector Voltage	V <sub>ECO</sub> ; 5 V
Collector Current	I <sub>c</sub> ; 20 mA
Collector Power Dissipation	P <sub>c</sub> ; 75 mW
Derate(25 to 75°C)	- 1.0 mW / °C

### Test Circuit

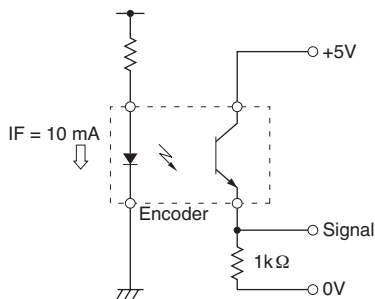

### Mechanical Spec.

Starting Torque	4.9×10 <sup>-4</sup> N · m Max	
Shaft Loading	Thrust axial	1.96N
	Radial	1.96N
Moment of Inertia	1×10 <sup>-8</sup> kg · m <sup>2</sup>	
Maximum RPM	6000r/min	
Net Weight	20g Max	

### Electrical Connections

1N Connector Hirose Electric Co., Ltd. DF3-4S-2C

Pin#	Color of Lead Wire	Description
1	Black	Anode
2	Brown	Cathode
3	Red	Collector
4	Orange	Emitter

2N Connector Hirose Electric Co., Ltd. DF3-5S-2C

Pin#	Color of Lead Wire	Description
1	Black	Anode
2	Brown	Cathode
3	Red	Collector (COM)
4	Orange	Emitter (A)
5	Yellow	Emitter (B)

2MN Connector Hirose Electric Co., Ltd. DF3-7S-2C

Pin#	Color of Lead Wire	Description
1	Black	Anode (COM)
2	Brown	Cathode (A, B)
3	Red	Collector (COM)
4	Orange	Emitter (A)
5	Yellow	Emitter (B)
6	Green	Emitter (Z)
7	Blue	Cathode (Z)

### Wave Form.

CW → Rotate Toward Clockwise Viewed from an Arrow

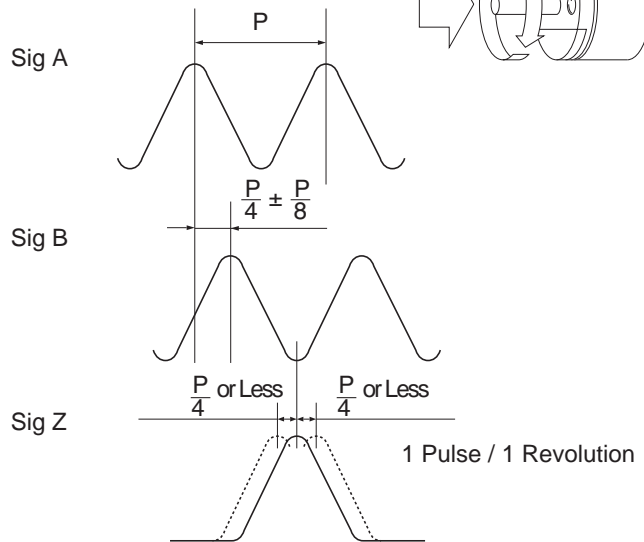
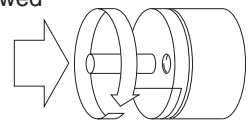

### Environmental Spec.

Operating Temperature	0°C ~ +50°C
Storage Temperature	- 20°C ~ +80°C
Humidity	RH 85% Max No Condensation
Vibration	10~50 Hz / 1.5mm 2 h
Shock	294m/s <sup>2</sup> , 11ms X, Y, Z Each 3 times
Degree of Protection	IP50