

**ABSOLUTE TYPE**

**AHS2** Model



**New Type of The 38 Series Hollow Shaft and Absolute Models.**

- Most Advanced 256 PPR High Resolution with Cover.

**Model**

**AHS2 - [ ] - G [ ] - [ ] [ ] - [ ] [ ] [ ] - 0 0**

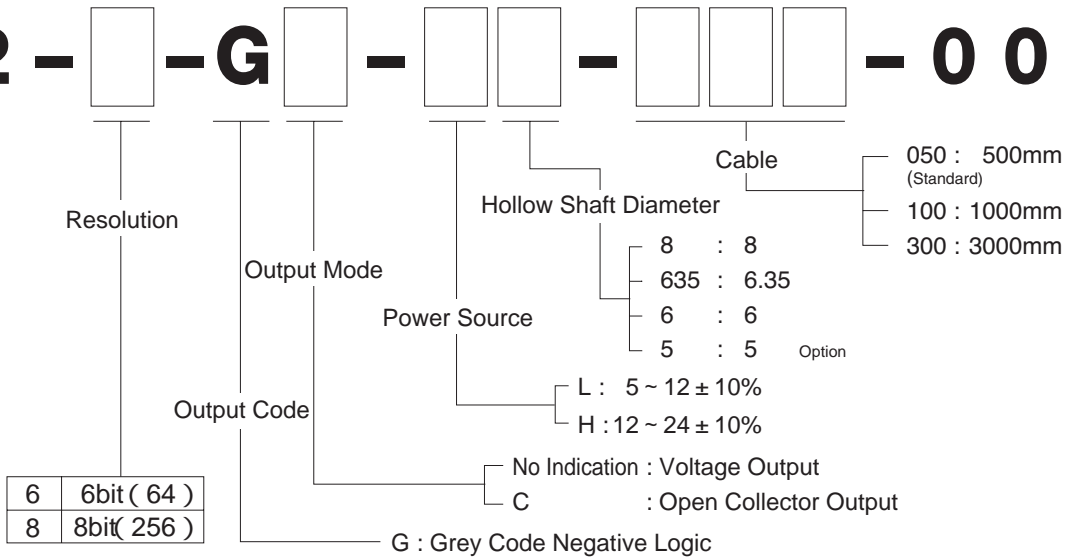

**External Dimension**

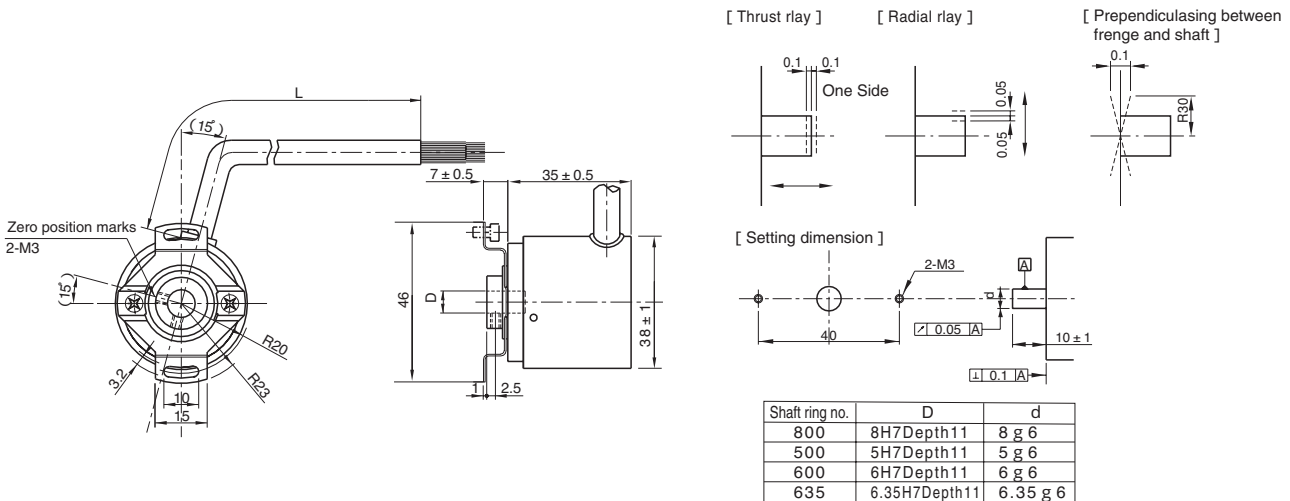

**Input & Output Current**

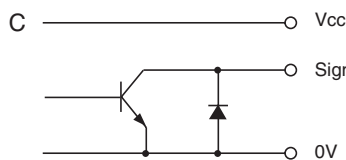
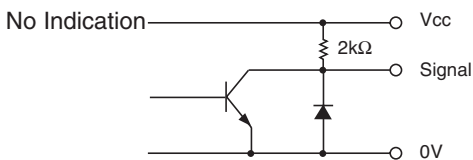

### Electrical Spec.

Supply Voltage	L : DC 4.5 ~ 13.2 V H : DC 10.8 ~ 26.4 V	
Requirement	100mA Max	
Output Voltage	"H"	Within - 1 power volt
	"L" ※1	0.5 V Max
Maximum Output Current	20 mA MAX	
Rise & Fall Time	1 μs Max	
Maximum Frequency Response <sup>2</sup>	5 kHz	

### Electrical Connections

Color of Lead Wire	Description
Red	Power Souce
Black	OV Common
Brown	Signal 2 <sup>0</sup>
Orange	Signal 2 <sup>1</sup>
Yellow	Signal 2 <sup>2</sup>
Green	Signal 2 <sup>3</sup>
Blue	Signal 2 <sup>4</sup>
Purple	Signal 2 <sup>5</sup>
Gray	Signal 2 <sup>6</sup> Only available for 256 split type
White	Signal 2 <sup>7</sup> Only available for 256 split type
Shielding Braid	F.G

※1) at Maximum Output Current    ※2) When The Lording is 5V 1K

### Wave Form.

(Extract)

Rotating Toward Clockwise  
Viewed from an Arrow

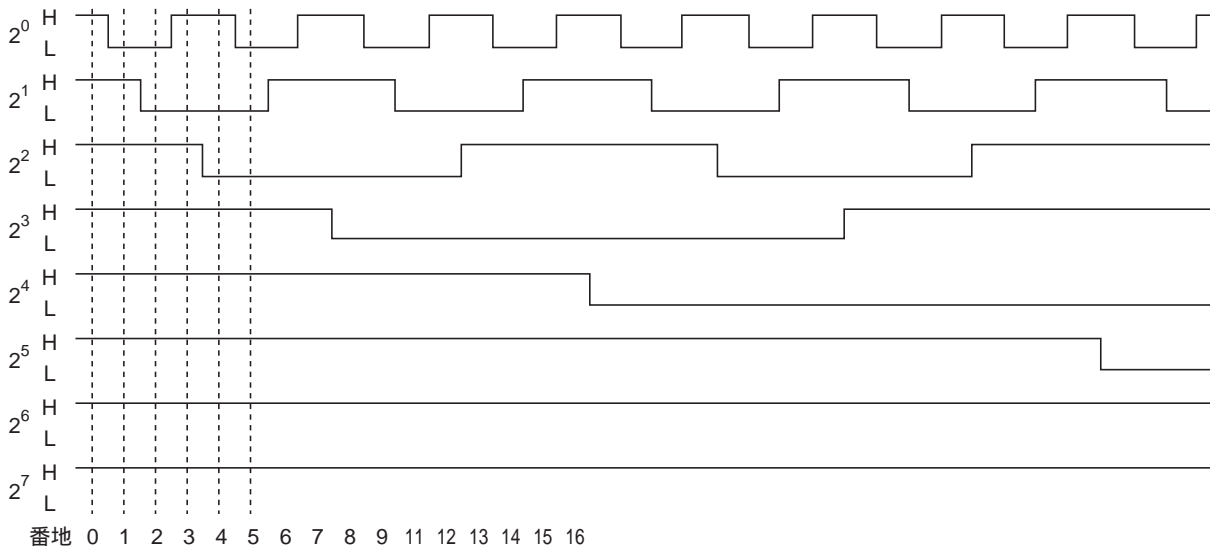
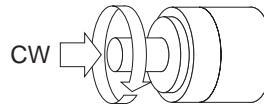

### Mechanical Spec.

Starting Torque	9.8×10 <sup>-4</sup> N · m Max	
Angular Acceleration	1×10 <sup>5</sup> rad/s <sup>2</sup>	
Shaft Loading	Thrust axial	9.8N
	Radial	29.4N
Moment of Inertia	8×10 <sup>-7</sup> kg · m <sup>2</sup>	
Maximum RPM	6000r/min	
Net Weight(W/O Cable)	120g Max	

### Environmental Spec.

Operating Temperature	-10°C ~ +55°C
Storage Temperature	-25°C ~ +80°C
Humidity	RH 85% Max No Condensation
Vibration	10 ~ 55 Hz / 1.5mm 2 h
Shock	490m/s <sup>2</sup> , 11ms X, Y, Z Each 3 times
Degree of Protection	IP50