

SHAFT TYPE

OEW-2 Model



Advanced Small Model

- Wide Variation of Outputs (6) and Resolution (20 ~ 3600 P/R).

Model

OEW2 - [] [] - [] [] [] - [] [] [] - [] **0 0**

Resolution		Signals Output Mode	
002	20P/R	05	500P/R
003	30P/R	0512	512P/R
0032	32P/R	06	600P/R
004	40P/R	08	800P/R
005	50P/R	09	900P/R
006	60P/R	10	1000P/R
01	100P/R	1024	1024P/R
0125	125P/R	12	1200P/R
02	200P/R	15	1500P/R
0250	250P/R	18	1800P/R
0256	256P/R	20	2000P/R
03	300P/R	2048	2048P/R
036	360P/R	25	2500P/R
04	400P/R	36	3600P/R

- Resolution**
- Signals Output Mode**
- No Indication : Voltage Output
 - C : Open Collector Output
 - HC : Open Collector Output / High Voltage
 - HCP : PNP Mode Open Collector Output / High Voltage
 - HT : Push-Pull Output / High Voltage
 - D : Line Driver Output
Low Power Consumption C-MOS Output Available
- Cable Length**
- 050 : 500mm (Standard)
 - 100 : 1000mm
 - 300 : 3000mm
- 0 0**
- No Indication: Other than D output
 - No Indication: D output with LS
 - C: D output with C-MOS
- 2** : AB90° Phase Difference
2M : AB90° Phase Difference + Zero Signal

External Dimension

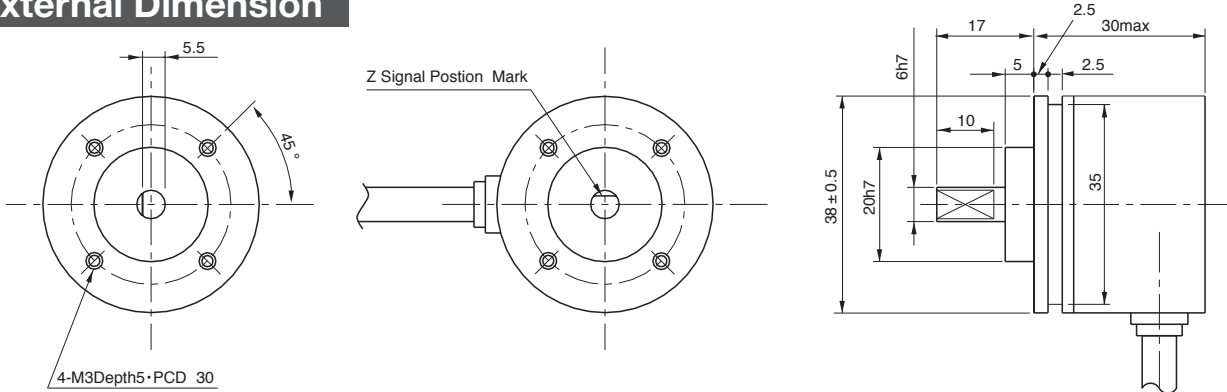

Circuit of Output Signal

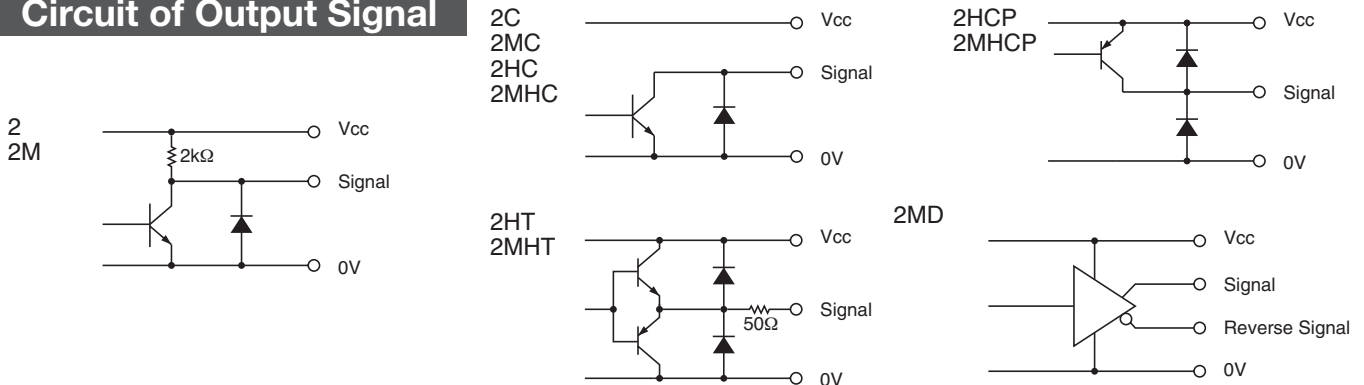

Electrical Spec.

※1) at Maximum Output Current ※2) Maximum Source Current

TYPE		2•2M	2C•2MC	2HC•2MHC	2HCP•2MHCP	2HT•2MHT	2MD
Supply Voltage		DC4.5 ~ 13.2 V			DC10.8 ~ 26.4 V		DC4.75 ~ 5.25V C-MOS DC4.5 ~ 5.5V
Requirement		80 mA Max	60 mA Max		100 mA Max	90 mA Max	150 mA Max C-MOS60 mA Max
Output Voltage	“H”	Within -1 Power Volt	—————		Within -1 ² Power Volt	Within -3 Power Volt	2.5 V or More
	“L” ※1	0.5 V Max			—————	3 V Max	0.5 V Max
Maximum Output Current		20 mA MAX				40 mA MAX	20 mA MAX
Rise & Fall Time		1 μs Max					200 ns Max
Maximum Frequency Response		200 kHz			50 kHz	200 kHz	
Withstanding Voltage of Output Tr.		—————	50 V MAX.		—————		

Wave Form.

CW → Rotating Toward Clockwise Viewed from an Arrow

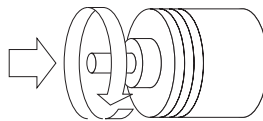

Rising point of A-Signal is always at one point while Z-Signal is at H-Level in CW.

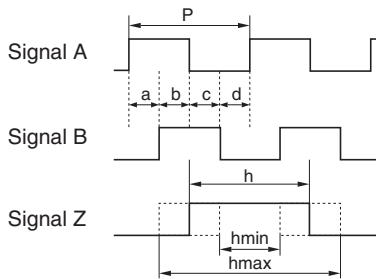

$$P = \frac{1}{1\text{Resolution}}$$

$$a, b, c, d = \frac{P}{4} \pm \frac{P}{8} \quad \frac{P}{2} \leq h \leq \frac{3P}{2}$$

Wave Ratio (Duty); 50 ± 25 (%)

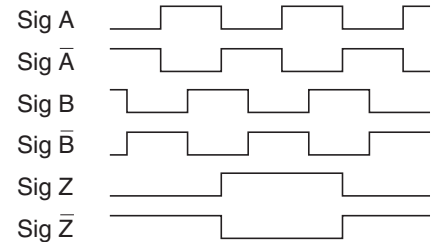

Electrical Connections

	Color of Lead Wire	Description
2	Red	Power Source
2M	Black	0V Common
2C	Green or Blue	Signal A
2MC	White	Signal B
2HC	Yellow	Signal Z
2MHC	Shielding Braid	NC
2HCP		
2MHCP		
2HT		
2MHT		

2MD	Color of Lead Wire	Description	Color of Lead Wire	Description
	Red	Power Source	White	Signal B
	Black	0V Common	Gray	Signal B-bar
	Green	Signal A	Yellow	Signal Z
	Blue	Signal A-bar	Orange	Signal Z-bar
	Shielding Braid	NC		

Mechanical Spec.

Starting Torque		9.8×10 ⁻⁴ N • m Max
Angular Acceleration		1×10 ⁵ rad/s ²
Shaft Loading	Thrust axial	19.6N
	Radial	29.4N
Moment of Inertia		8×10 ⁻⁷ kg • m ²
Maximum RPM		6000r/min
Net Weight		100g Max

Environmental Spec.

Operating Temperature	-10°C ~ +70°C
Storage Temperature	-30°C ~ +80°C
Humidity	RH 85% Max No Condensation
Vibration	10~50 Hz / 1.5mm 2 h
Shock	490m/s ² , 11ms X, Y, Z Each 3 times
Degree of Protection	IP50